

V922-D4129 (EMEA) NETWORK 30x BOX CAMERA



Vicon's V922-D4129 high definition (HD) WDR network camera is designed for security installations that need a compact vandal resistant camera that delivers outstanding imaging at 1080P resolution and is able to optically zoom up to 30 times remotely.

The V922-D4129 camera provides triple-streaming video and supports H.264 compression technology, drastically reducing file sizes and conserving valuable network bandwidth. Users can receive multiple streams simultaneously in different resolutions, frame rates and image qualities for viewing on different platforms. A microphone can be connected to the camera to capture audio.

Installation is made easy and cost effective with Power over Ethernet (IEEE 802.3af), which eliminates the need for power cables. Additionally, a composite output is provided for installation using a spot monitor (NTSC/PAL selectable). This box camera fits unobtrusively and is ideal for use with an outdoor housing for observing high security areas that require long range identification of objects. The camera is ONVIF compliant and can be used with many popular VMS systems.

Product at a Glance

- ▶ 1080p resolution (1920 x 1080)
- ▶ Colour 0.35 Lux, B/W 0.013 lux
- ▶ 4.3-129mm 30x AF Optical Zoom lens
- ▶ 120 dB WDR
- ▶ Power-over-Ethernet (IEEE 802.3af), 12VDC/24VAC
- ▶ RS485/RS422
- ▶ uSD Card Edge Recording
- ▶ Privacy Masking
- ▶ Audio In/Out
- ▶ Alarm In/Out
- ▶ Analogue Video Composite Output

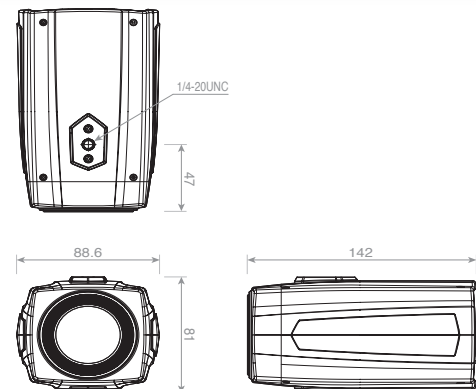

Unit : mm

Ordering Information

Description

1080P network camera, 4-129mm AF Lens (30x), 120 dB WDR, POE (8W)/12VDC/24VAC

Model Number

V922-D4129

Model	V922-D4129
Image Sensor:	1/2.8" Sony STARVIS CMOS Sensor
Max Resolution:	1920 x 1080
Image Settings:	Adjustable bit rate. Flip and mirror. Configurable brightness, contrast, color, hue, sharpness. White balance. AGC. AES. Automatic or manual day/night mode. 3DNR, BLC (Backlight Compensation). Digital zoom. Motion detection. Slow Shutter. Privacy Masking
Shutter Speed:	Auto(1/50,000~x8sec), Manual
Scanning Mode:	Progressive scan
Electronic Zoom:	2 ~ 16X (client software)
Day/Night Performance:	IR cut filter, True Day/Night
S/N Ratio:	120 dB WDR
Minimum Illumination:	Colour : 0.35Lux, B/W : 0.013Lux
Lens	
Focal Length:	4.3~129mm 30x AF Optical Zoom
Minimum Focus Distance:	100mm(Wide), 1000mm(Tele)
Iris:	DC auto-iris
Horizontal Field of View:	2.23° - 65.1°
Network Video Transmission	
Network:	10Base-T, 100Base-TX, RJ-45
Image Compression:	H.264 (High Profile); M-JPEG (Triple Stream(H.264x2, MJPEGx1))
Resolution:	1920x1080(Full HD), 1280x1024(SXGA), 1280x720(HD), 704x480/576(D1), 640x480(VGA), 320x240(QVGA)
Protocol:	IPv4, IPv6, TCP, HTTP, HTTPS, UPnP, RTSP/RTP/RTCP, IGMP, SMTP, DHCP, NTP, DNS, DDNS, UDP, ARP
Frame Rate:	Maximum 60fps
Users:	Live viewing for up to 10 Users, Playback : 3 Users (unicast)
Web Browser:	Internet Explorer® 7.0 and above, Chrome®, Firefox®
Security:	IP address filtering, HTTPS encrypted data transmission, password protection
Mechanical and Electrical	
Dimensions:	88.6(W) x 81(H) x 142(D)mm
Weight:	0.7 Kg
Input Power:	PoE (IEEE 802.3af Class 0), 12VDC, 24VAC
Power Consumption:	Max 8W
RS485/RS422:	Yes
Alarm Relay	1 TTL Sensor Input Terminal, 1 Open Collector Output Terminal
Audio	3.5mm Line in and 3.5mm Line out (Audio Alert: 3 Pre-Recorder Voice File Selectable)
Audio Out	G.711 codec, 64kbps bit rate
u-SD Card	SDHC(Max. 32GB)
Composite Video Output	Yes
Environmental	
Operating Conditions:	Temp: 32 to 122° F (0 to 60° C); Humidity: less than 90%, non-condensing
Approvals:	FCC Class A, CE, UL
Warranty:	3 years

Data Sheet Number: V274-10
Dated: 1/2016

Vicon Data Sheet Part Number: 8009-7274-20-00
Specifications subject to change without notice.

Vicon and their logos are registered trademarks of Vicon Industries Inc.
Microsoft and Windows are registered trademarks of Microsoft Corporation.
Copyright © 2016 Vicon Industries Inc. All rights reserved.